

## CONFIGURATION

Multi-function Instrument	Driving OPS
Lifting/Steering Computer Controlled	Wide Field Mast
Pedal Rubber	Gear Pump with Low Noise
Standard Battery	Load Sensing Hydraulic System
Emergency Power Off	Charging Indicator
Standard Seat	Electric Horn
Full-hydraulic Power Steering	Reversing Buzzer
Standard Forks	Traction Pin
Adjustable Steering Column	Tool Box
Lifting and Tilting Joysticks	Solid Tires
Two Piece Multiplex Valve	

## OPTIONAL

Rear Working Lamp	Full Set LED Lamps
Working Warning Light	Full Set OPS (drive and lift)
Suspension Seat	Widen and Lengthen Backrest
Green Solid Tires	Widen Fork Frame
2 Stage Free Mast	Lengthen Fork Jacket
3 Stage Free Mast	Tilting Cylinder Sleeve
Lifting Potentiometer	Steering Cylinder Sleeve
Battery Charger	Custom Colors
Valve and piping Reserving	Multiple Work Attachments
Cabin	Warm-air Blower

## PRODUCT FEATURES

Advanced AC dual drive motor, which can produce strong traction and power.
Ultra-small turning radius, improve passability and space utilization.
Regenerative braking function, prolong effective using time of battery.
Intelligent LCD, can display the fault code, improve the maintenance efficiency.
Powerful AC pump motor provides greater torque, making lifting and dropping of forks more smooth.
Anti-skid function of ramp enables machine to slide smoothly and automatically on ramp.

The following blank can be used for notes or comments.

**For more information on Lonking products,  
Please contact our local agent:**

Lonking, Lonking LG Series and their respective logos, as well as corporate identity in this leaflet are trademarks of Lonking Holdings Ltd., and may not be used without written permission.  
2020/06

Specifications and design are subject to change without prior notice.  
Machines shown may not include optional accessories.

# LONGKING 龙工

## LG/16/18/20BE3

BALANCEWEIGHT TYPE FORKLIFT TRUCK WITH BATTERY

Efficiency Rules the Future



LONGKING (FU JIAN) INTERNATIONAL TRADE CO., LTD.

**LONGKING HOLDINGS LIMITED**

Add: 26 Minyi Road, Xinqiao, Songjiang Industrial Zone, Shanghai

Tel: +86-21-3760 2242 E-mail: export@lonking.cn

<http://www.lonkinggroup.com>

	LG16BE3	LG18BE3	LG20BE3
Rated Capacity (kg)	1600	1800	2000
Load Center (mm)	500	500	500
Power Type	Electric (AC)		

## OVERALL SPECIFICATIONS

No.	Item	Code	Unit			
1.01	Manufacturer			LONKING		
1.02	Model			LG16BE3	LG18BE3	LG20BE3
1.03	Power type			Electric (AC)		
1.04	Rated capacity	Q	kg	1600	1800	2000
1.05	Load center	J	mm	500	500	500
2.01	STD Max height (with backrest)		mm	4028	4028	4028
2.02	STD Max lifting height	h1	mm	3000	3000	3000
2.03	Overhead guard height	h4	mm	2044	2044	2044
2.04	Overall length (with fork)	L1	mm	2875	2875	3133
2.05	Wheelbase	L2	mm	1400	1400	1508
2.06	Front overhang	L3	mm	365	365	365
2.07	Rear overhang	L4	mm	190	190	190
2.08	Min.ground clearance (Frame/Mast)	m1/m2	mm	85/105	85/105	85/105
2.09	Overall width	W1	mm	1060	1060	1120
2.10	Adjusting range of fork (outside)		mm	200-970	200-970	200-970
2.11	STD Fork size (L5*W*T)		mm	920×100×35		1070×120×40
2.12	Front wheel tread	S	mm	910	910	920
2.13	Rear wheel tread	P	mm	175	175	175
2.14	Min.turning radius	R1	mm	1590	1590	1698
2.15	Min aisle width for pallet 1000×1200,crossways		mm	3280	3280	3380
2.16	Min aisle width for pallet 800×1200,lengthways		mm	3400	3400	3508
3.01	Wheels number, front/rear (X=driven wheels)			X=2/1		
3.02	Tires type			Solid Tires		
3.03	Tires size, front			18×7-8	18×7-8	200/50-10
3.04	Tires size, rear			15×4.5-8	15×4.5-8	15×4.5-8
4.01	Max.traveling speed, loaded/unloaded		km/h	13.5/13.5	13.5/13.5	13/15
4.02	Max.lifting speed, loaded/unloaded		mm/s	300/440	300/440	300/440
4.03	Lowering speed, loaded/unloaded		mm/s	Loaded≤600/Unloaded≥300		
4.04	Max.gradient, loaded/unloaded		%	20/20	20/20	20/20
4.05	STD operating weight (with oil & water)		kg	3180	3290	3380
4.06	Axles loading,front/rear (loaded)		kg	4300/620	4570/605	4920/545
4.07	Axles loading,front/rear (unloaded)		kg	1600/1600	1600/1710	1710/1690
4.08	Drive motor		kw	5.4×2	5.4×2	5.4×2
4.09	Lift motor		kw	11	11	11
4.10	Controller			inmotion	inmotion	inmotion
4.11	Battery votage/capacity		V/Ah	48/600	48/600	48/600

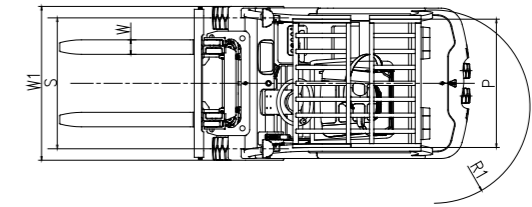
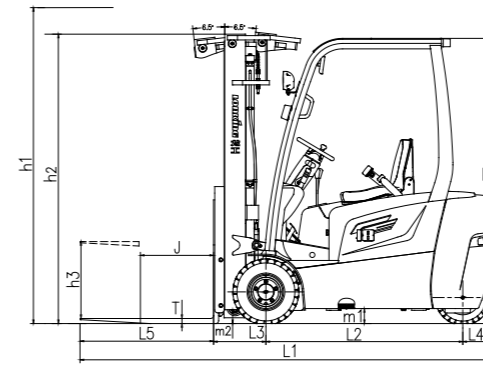

## MAST SPECIFICATIONS

### 2 Stage Standard Mast-Super Wide Field

Mast Model	h1 Max Lifting Height(mm)	Load Capacity (J=500mm) (kg)			h2 Lowered Mast	h3 Free Lifting Height, without	Mast tilt α/β (°)
		LG16BE3	LG18BE3	LG20BE3			
M250	2500	1600	1750	2000	1760	85	5/7
M270	2700	1600	1750	2000	1860	85	5/7
<b>M300</b>	<b>3000</b>	<b>1600</b>	<b>1750</b>	<b>2000</b>	<b>2010</b>	<b>85</b>	<b>5/7</b>
M330	3300	1600	1750	2000	2160	85	5/7
M350	3500	1600	1750	2000	2260	85	5/7
M370	3700	1600	1750	2000	2360	85	5/7
M400	4000	1600	1750	1950	2560	85	3/5
M425	4250	1600	1750	1900	2685	85	3/5
M450	4500	1500	1750	1850	2810	85	3/5
M475	4750	1400	1750	1750	2935	85	3/5
M500	5000	1400	1600	1600	3060	85	3/5

### 2 Stage Free Mast-Super Free Lifting Height

Mast Model	h1 Max Lifting Height(mm)	Load Capacity (J=500mm) (kg)			h2 Lowered Mast	h3 Free Lifting Height, without	Mast tilt α/β (°)
		LG16BE3	LG18BE3	LG20BE3			
ZM250	2500	1600	1750	2000	1760	1125	5/7
ZM275	2750	1600	1750	2000	1885	1250	5/7
<b>ZM300</b>	<b>3000</b>	<b>1600</b>	<b>1750</b>	<b>2000</b>	<b>2010</b>	<b>1375</b>	<b>5/7</b>
ZM330	3300	1600	1750	2000	2160	1525	5/7
ZM350	3500	1600	1750	2000	2260	1625	5/7
ZM375	3750	1600	1750	2000	2385	1750	5/7
ZM400	4000	1600	1750	2000	2560	1925	3/5

Note:With backrest, free lifting height reduces 348mm.

### 3 Stage Free Mast-Super Free Lifting Height

Mast Model	h1 Max Lifting Height(mm)	Load Capacity (J=500mm) (kg)			h2 Lowered Mast	h3 Free Lifting Height, without	Mast tilt α/β (°)
		LG16BE3	LG18BE3	LG20BE3			
ZSM360	3600	1500	1700	1900	1790	1142	3/5
ZSM400	4000	1400	1600	1800	1828	1280	3/5
ZSM430	4300	1300	1500	1700	2040	1392	3/5
ZSM450	4500	1200	1400	1600	2090	1442	3/5
<b>ZSM470</b>	<b>4700</b>	<b>1150</b>	<b>1350</b>	<b>1550</b>	<b>2162</b>	<b>1512</b>	<b>3/5</b>
ZSM480	4800	1100	1300	1500	2190	1542	3/5
ZSM500	5000	900	1100	1300	2290	1642	3/5
ZSM540	5400	800	900	1100	2415	1767	3/3
ZSM600	6000	500	600	850	2640	1992	3/3
ZSM650	6500	400	500	600	2840	2192	3/3

Note:With backrest, free lifting height reduces 348mm.